

Theoretical Analysis of Transportation of Cotton to Bank and Warehouses

Mominov M. R

"Cotton Industry Scientific Center" JSC

Topvoldiev A. A

Fergana Polytechnic Institute

Abstract: The analysis of the processes related to the process of ginning cotton in open and closed warehouses showed that the gin formation in the process of cotton preparation is the process that requires the most manual labor. In this article, based on the existing physical laws, the answer to such questions as the heavy forces of the transported cotton and the movement of the cotton was found.

Keywords: speed, time, angle, gas, cotton, conveyor, open warehouse, shutter, force, power, electric motor.

Using scientifically based methods for cotton ginning enterprises in cotton-textile clusters, on the basis of technologically correct connection of processes with each other, timely acceptance, quality storage of raw materials and negative impact on cotton components during its processing. Attention has been paid to the improvement of production by preventing "secret" [1]. Currently, there are many problems in the technology of growing, picking, storing and processing raw cotton. Preparation of cotton for storage directly affects the quality indicators of more than 35 products intended to be obtained from it [2,3,4]. Therefore, the importance of preparing cotton for storage is considered high, and KLP-650, TLH-18 mobile receiving-transmitting devices are widely used for receiving and delivering transported cotton raw materials to the next vehicles [5-6].

Depending on the amount of moisture and impurities in the cotton raw material, it moves from one point to another point under the influence of its own weight when it takes a vertical view from the horizon at a certain angle. In this process, the movement of cotton along the surface of the belt conveyor creates a condition for its transport. According to it, the following equation is derived:

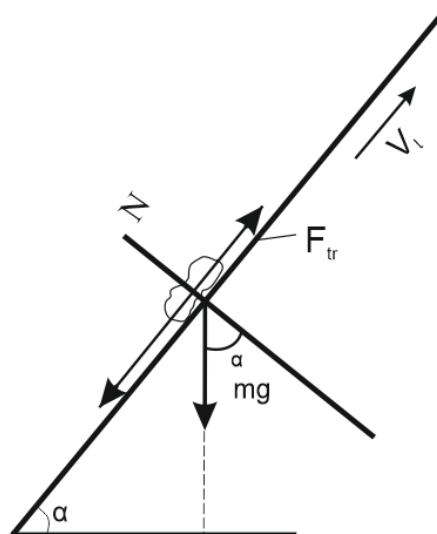

Figure 1. The scheme of the dependence of the weight of the transported cotton on the angle of inclination of the conveyor



$$M\ddot{x} = -mg \cdot \sin \alpha + f \cdot mg \cdot \cos \alpha + F \quad (1)$$

$$mg \cdot \sin \alpha < fmg \cos \alpha \quad (2)$$

$$f < tg \alpha \quad (3)$$

f - coefficient of friction of cotton on the tape surface

In the research conducted by Miroshichenko, the coefficient of friction of cotton f takes values of - 1.0:1.2.

This coefficient takes different values depending on the angle of deviation of the belt conveyor relative to the horizon.

$$\alpha = 45 \div 50^\circ$$

So, when the belt conveyor 45° is less than the slope angle, the transport condition is realized.

In the equation:

m - mass of a piece of cotton, kg ;

α - transverse deviation angle, $grad$;

F - tape pulling force, A ;

Electrical energy is converted into mechanical energy in moving the tape. Here, F -force depends on the power of the conveyor electric motor.

$$F = \frac{Ma}{R} = \frac{2Ma}{D}, \quad (4)$$

$$Ma = \frac{N}{\omega} = N \cdot \omega^{-1} \cdot \eta$$

$$\omega = \frac{\pi n}{30} \quad (5)$$

$$Ma = \eta \cdot N \cdot \frac{30}{\pi n} = 9,554 \cdot \eta \cdot \frac{N}{n} = 9,554 \cdot n^{-1} \cdot \eta \cdot N$$

$$F = 9,554 \cdot \eta \cdot N \cdot \frac{2}{Dn} = 19,108 \cdot \eta \cdot \frac{N}{Dn} \quad (6)$$

Here:

N - power of the electrometer, kW

D - the diameter of the leading drum (in the belt conveyor), m ;

η - coefficient of use of the drive ;

n - the number of leading baaban rotations, $min^{-1}(ayl/min)$;

M_a - drive drum rotation mament, $N \cdot m$;



If we calculate the electric power in kW:

$$F = 19108,280 \cdot \eta \cdot \frac{N}{Dn}, \quad (7)$$

The traction force varies depending on the mass of cotton applied to the tape and the angle of deviation of the conveyor.

$$F = f(m; \alpha) \quad (8)$$

(1) we change the form in the equation

$$\begin{aligned} \ddot{X} &= -g \cdot \sin \alpha + fg \cdot \cos \alpha + \frac{Ft}{m} = g(f \cos \alpha - \sin \alpha) + \frac{Ft}{m} \\ \frac{dv}{dt} &= g(f \cdot \cos \alpha - \sin \alpha) + \frac{Ft}{m}, \quad (9) \end{aligned}$$

$$dv = g(f \cdot \cos \alpha - \sin \alpha) dt = \frac{Ft}{m} dt$$

The tensile force F_t increases proportionally to the mass of cotton transferred to the tape, so we assume that they are relatively constant:

$$\frac{Ft}{m} = \text{const} \quad (11)$$

In that case, we make the following formula by integrating (10).

$$V = g(f \cdot \cos \alpha - \sin \alpha)t + \frac{Ft}{m} t + c, \quad (12)$$

$t = 0$ when the tape is not moving $v = v_0 = 0$.

If taken against a moving tape, it $v = v_0 \neq 0$ will be empty.

According to him:

$$V = g(f \cdot \cos \alpha - \sin \alpha)t + \frac{Ft}{m} t + v_0, \quad (13)$$

If $V = \frac{ds}{dt}$ we consider

$$ds/dt = g(f \cdot \cos \alpha - \sin \alpha) t + \frac{Ft}{m} t + v_0 \quad (14)$$

Integrating this equation over time, we get the following.

$$S = g(f \cdot \cos \alpha - \sin \alpha) \frac{t^2}{2} + \frac{Ft}{m} \cdot \frac{t^2}{2} + v_0 \cdot t + C_2 \quad (15)$$

$t = 0$ when

$S = c_2 = S_0 = 0$ will be

Accordingly:

$$S = g(f \cdot \cos \alpha - \sin \alpha) \frac{t^2}{2} + \frac{Ft}{m} \cdot \frac{t^2}{2} + v_0 \cdot t, \quad (16)$$

This equation represents the movement of cotton along the ribbon.

$S = L_l$ when the cotton leaves the tape, that is, it falls to the gharam.

$$S = L_l = [g(f \cdot \cos \alpha - \sin \alpha) + \frac{Ft}{m}] \cdot \frac{t^2}{2} + v_0 \cdot t, \quad (17)$$

This is a quadratic equation and can be solved in the standard way.

$L_l = 18 \text{ m}; g = 9,81 \text{ m/sec}^2; \alpha = 20 \div 45; f = 1 \div 1,2; N = 6 \text{ kVt};$

$\eta = 0.7; n = 80 \text{ ayl/min}; D = 0,2 \text{ m}; V_0 = 0 \div 4 \text{ m/s}$

$$\frac{g}{2}(f \cdot \cos \alpha - \sin \alpha) + \frac{Ft}{m} = a; \quad b; \quad L_l = c \text{ if we define} \\ at^2 + bt + c = 0 \quad (18)$$

an equation of the form is formed.

The equation is processed on the computer in Maple 2020 with the following parameters. According to it, we accept the value $t=3.6$ as the average parameter.

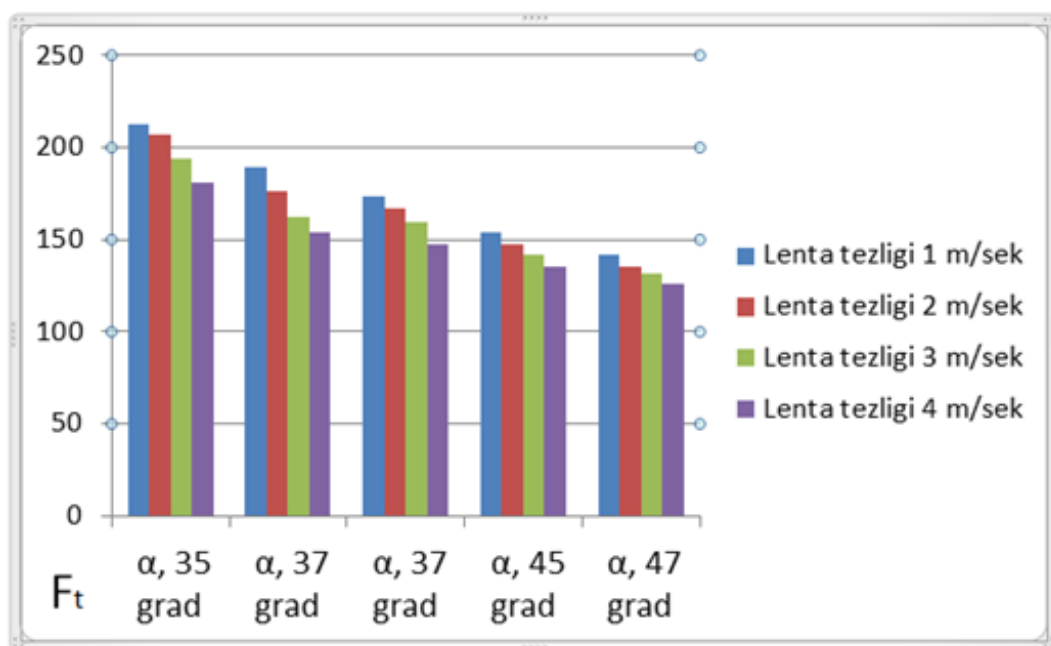

Figure 2. The influence of the angle of inclination of the conveyor belt relative to the horizon on the traction force

Figure 2 shows that a change in the angle of deviation of a belt conveyor causes the pulling force values to increase. If the speed of the cotton being transported is increased to 1 m/s, we can see that the weight of the cotton against the tape is reaching its maximum value. The speed of the belt conveyor is 3-4 m/sec, and the angle of deviation of the conveyor is 40-47⁰. The value of the pulling force of the cotton against the belt is reaching its minimum.

According to the obtained values, we accept equations (13) and (17) for analysis.

$$\left\{ \begin{array}{l} V = g(f \cdot \cos \alpha - \sin \alpha)t + \frac{Ft}{m}t + v_0 \\ S = 0,5[(f \cdot \cos \alpha - \sin \alpha) + \frac{Ft}{m}] \cdot t^2 + v_0 \cdot t \end{array} \right. \quad (19)$$

Condition: $f > tg \alpha$

Figure 3 shows the graphs of cotton speed V and its displacement S over time for different input parameters.

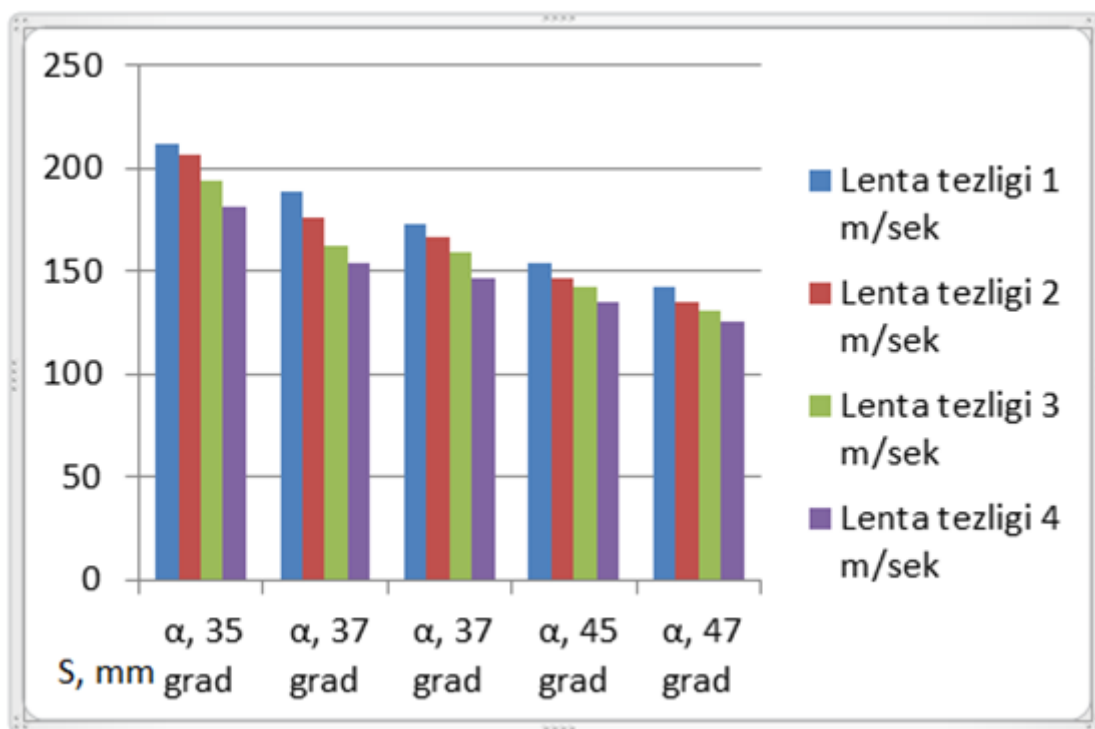

Figure 3. Effect of cotton speed and conveyor deflection angle on displacement S

From the histogram presented in Figure 3, it can be seen that the increase in the deviation angle of the belt conveyor leads to an increase in its distance. If the speed of the transported cotton is measured with a speed of 3-4 m/sec, its moving distance takes a value of 135-150 mm. This shows that the speed of the belt conveyor is 3-4 m/sec, and the angle of deviation of the conveyor is 40-47⁰ in reception and transmission works, which shows that the equipment will work without adjustment for a long time.

LIST OF REFERENCES USED

1. Salimov AM Development of technological conditions and conditions podgotovki hlopka-s y rsa vlnajnostyu 10-15 % k hraneniyu: Diss...kand.techn.nauk: - Tashkent, 1987 - 167 p.
2. Result y op y tov pressovaniya khlopka-s y rsa: Otchet op y tnogo zavoda/SNIIXprom; - Tashkent, 1982. - 16 p.



3. Machine for nabivki hlopka-s y rsa v meshki / Gizlegprom; - Tashkent, 1955. - 58 p.
4. Azizkhodjaev UX K voprosu mekhanizatsii operatsii buntovaniya hlopkas y rsa i vliyanie khanicheskogo uplotneniya na ego kachestvo: Diss...kand.techn.nauk: - Tashkent, 1967. - 166 p.
5. Israilov SH.V. K voprosu uplotneniya hlopka-s y rsa v kuzovakh kolesnogo transporta i usloviya sokhraneniya prirodni y x kachestv hlopka pri etom: Autoref. diss...cand.techn.nauk: - Tashkent, 1968. - 33 p.
6. As 647368. Ustroystvo dlya uplotneniya voloknistogo materiala / XK Dav y dbaev, D. Yakubov, GP Nesterov i YU.G. Belokurov; SNIIXprom., publ. BI, 1979, No. 6. S.31.
7. Instruction po uborke i zagotovke hlopka-s y rsa /- M., SNIITEI, 1982. 1 – 71 p.
8. Khodzhiev MT Development theory and justification of the parameters of the mechanized technological process of minimodule compaction and storage of cotton-syrsa. Diss...dtn: - Tashkent, 1998, -318 p.
9. Ollayorov MA, Khojiev MT, Ruzmetov ME. Improvement of the device for transferring cotton from closed storage to production: Proceedings of the republican scientific-practical conference "21st century-the century of the young intellectual generation", Tashkent-2016. TTESI March 29, pp. 129-131.
10. Suslin AN Issledovanie iv y bor optimaln y x parameters rabocheho organa dlya r y tya tunneley v buntax hlopka-s y rsa. Cand. diss., Tashkent, 1972. - p.8.
11. Patent UZ FAP00514. Fiber material transfer and distribution device / Khodzhiev MT, Juraev AJ, Rakhmanov XK, Ruzmetov ME//Official bulletin. – 2010, - 1.